

D-SUBMINIATURE COMBINATION CONNECTORS

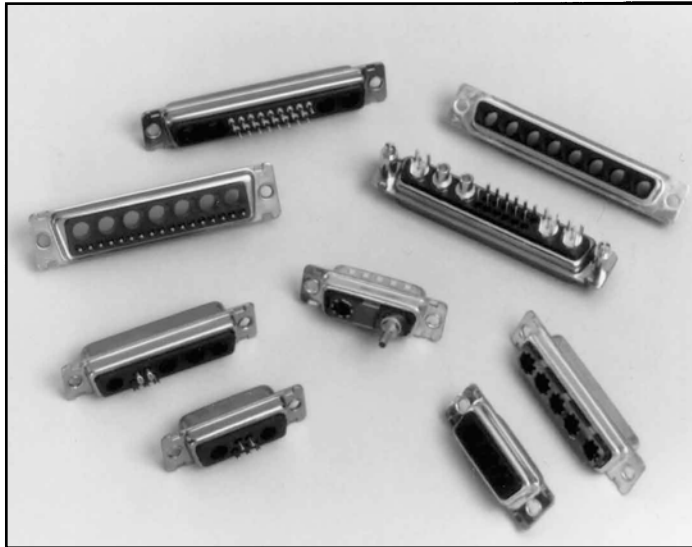

Contents:

- Specifications
- Selection Guide
- Part Number Selection System
- Signal Contact Modifiers and Size 8 Contact Modifiers
- Part Number Example
- Shell Dimensions
- Mounting Hardware Options
- D-subminiature Guide Pin Plates
(Male and Female Specifications)
- Grounding Straps
- EMI/RFI Barrier Plating
- Capacitively Decoupled Capabilities
- Non-Magnetic Connectors
- Military Combination Connectors
(DESC Cross Reference)
- Stabilizing Rings
- Contact Extraction Tool

D – SUBMINIATURE COMBINATION CONNECTORS

SPECIFICATIONS SUBJECT TO CHANGE WITHOUT NOTICE

CONNECTOR IS COMPATIBLE WITH THE REQUIREMENTS OF MIL-C-24308, LATEST REVISION.

MATERIALS

HOUSING

Machined Contacts: Copper Alloy per ASTM B 140.
Stamped and Formed Contacts:
Beryllium Copper per QQ-C-533 or Phosphor Bronze per
QQ-B-750.
Insert: Thermoplastic Type GPT-30F per MIL-M- 24519.
Shells: Cold Drawn Steel per ASTM A 568 and A 620.

HARDWARE

Threaded Inserts / Standoffs: Brass per ASTM B 16 or Steel
per ASTM A 108.
Brackets: Cold Rolled Steel per ASTM A 568.
Push On Fasteners: Copper Alloy per QQ-B-750.
Ground Straps: Beryllium Copper per QQ-C-530.

FINISHES/COLORS

HOUSING

Machined 20 Gage Signal Pins:
Commercial Grade: Gold 0.000030 Thick or
0.000050 Thick per MIL-G-45204 over Nickel
per QQ-N-290.
Stamped and Formed 20 Gage Signal Pins:
Flash: Gold 0.000010 Thick
Commercial Grade 0.000030 Thick or
0.000050 Thick per MIL-G-45204 over Nickel
per QQ-N-290 with 90/10 Tin/Lead per MIL-T-10727 on Tail
Section.
Insulator Color: Black.
Shells: Yellow Chromate over Zinc per ASTM B 633 or Yellow
Chromate over Cadmium per QQ-P-416 or Tin per ASTM B 545.

HARDWARE

Threaded Inserts / Standoffs: Nickel per QQ-N-290.
Brackets: Yellow Chromate over Zinc per QQ-Z-325 or
Yellow Chromate over Cadmium per QQ-P-416.
Ground Straps: None.
Push On Fasteners: Tin per ASTM B 545.

ELECTRICAL

Dielectric Strength: 500 V RMS Minimum at Sea
Level. 200 V RMS Minimum at 70,000 Feet.
Insulation Resistance: 1 Megohm Minimum.
Current Rating:
Solder Cup 7.5 Amps.
P.C. Tail 0.040 (1.02) Dia. 7.5 Amps.
P.C. Tail 0.030 (.76) Dia. 5.0 Amps.
P.C. Tail 0.024 (.61) Dia. 2.5 Amps.

MECHANICAL

Operating Temperature: -65° F to 250° F
(-54° C to 121° C).

Durability: 500 Mating Cycles per MIL-STD 1344
Method 2016.

ENGAGEMENT/SEPARATION FORCES

Maximum Individual Engagement Force: 18 Oz.
(Using Maximum Diameter Pin).
Minimum Separation Force: .7 Oz.
(Using Minimum Diameter Pin).

ENVIRONMENTAL

Humidity per MIL-STD-1344, Condition II Method 1002.
Temperature Cycling per MIL-STD-1344, Condition A, Method 1003.
Salt Spray per MIL-STD-1344, Condition B, Method 1001.
Vibration per MIL-STD-1344, Condition 4, Method 2005.
Shock per MIL-STD-1344, Condition E, Method 2004.



D-SUBMINIATURE SELECTION GUIDE

SIZE 8

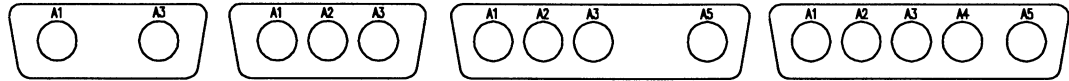

Shell Size	A	A	B	B
Arrangement	2W2	3W3	4W4	5W5
Insulator Type Modifier	22	33	44	55
Coax or HV Cavities	2	3	4	5

COMBINATIONS

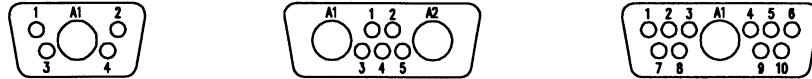

Shell Size	E	A	A
No. of Size 20 Contacts	4	5	10
Arrangement	5W1	7W2	11W1
Insulator Type Modifier	51	72	111
Coax or HV Cavities	1	2	1



Shell Size	B	C
No. of Size 20 Contacts	20	7
Arrangement	21W1	13W6
Insulator Type Modifier	211	136
Coax or HV Cavities	1	6



Shell Size	C	C
No. of Size 20 Contacts	17	22
Arrangement	21W4	25W3
Insulator Type Modifier	214	253
Coax or HV Cavities	4	3



Shell Size	D	D
No. of Size 20 Contacts	32	41
Arrangement	36W4	43W2
Insulator Type Modifier	364	432
Coax or HV Cavities	4	2

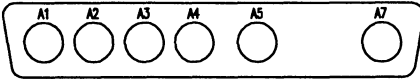
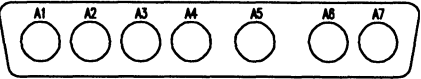
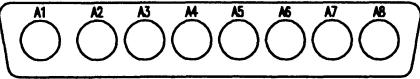

D-SUBMINIATURE SELECTION GUIDE

		
C	C	C
6W6	7W7	8W8
66	77	88
6	7	8

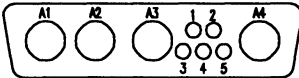
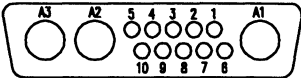
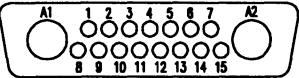
		
B	B	B
5	10	15
9W4	13W3	17W2
94	133	172
4	3	2

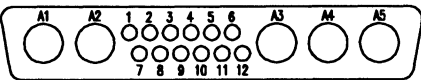
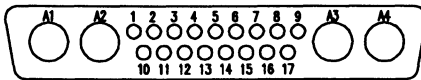
	
C	C
12	17
17W5	21WA4
175	2A4
5	4

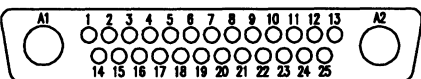
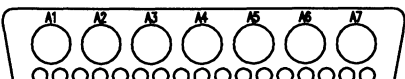
	
C	D
25	17
27W2	24W7
272	247
2	7

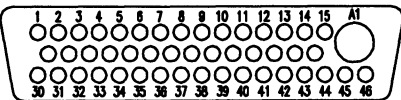
	<p style="margin: 0;">CUSTOM COMBINATIONS AVAILABLE</p>
D	All Sizes
46	Please Contact Factory
47W1	
471	
1	



D-SUB CONNECTOR PART NUMBER SELECTION SYSTEM

To order a combination connector, please fill in the blanks to determine your part number.

	□	□□□	□	□	□	□□	□	□
<u>Series Prefix</u>								<u>Mounting Hardware Modifier</u>
P = Monoblock Insulator.								For Unique Hardware Requirements, Contact Factory For More Options.
PR = RoHS Compliant Monoblock Insulator.								Blank= 0.120 Diameter Through Hole (Rivet, Standard).
D = Doubleblock Insulator (Excluded For Right Angle Contacts).								A = 0.165 Through Hole (Tab).
DR = RoHS Compliant Doubleblock Insulator (Excluded For Right Angle Contacts).								B = #4-40 Cinch Nut.
E = EMI Shielded Insulator (Only Available For Size 8 Contacts Without Any Signal Contacts).								C = Straight #4-40 Swaged Standoff Fastener.
ER = RoHS Compliant EMI Shielded Insulator (Only Available For Size 8 Contacts Without Any Signal Contacts) (Not Currently Available).								D = Dual Float Mount.
H = High Temperature Insulator.								E = #4-40 Standoff, Right Angle Bracket With 0.420 Hole Location.
HR = RoHS Compliant High Temperature Insulator.								F = #4-40 Standoff, Right Angle Bracket With 0.340 Hole Location.
N = Non-Magnetic D-Sub Connector.								G = #4-40 Standoff, Right Angle Bracket With 0.420 Hole Location and Push-On Fastener Board Lock.
NR = RoHS Compliant Non-Magnetic D-Sub Connector (Not Currently Available).								H = #4-40 Standoff, Right Angle Bracket With 0.340 Hole Location and Push-On Fastener Board Lock.
<u>Insulator Type Modifier</u>								J = Internal D-Sub Guide Pin With Straight #4-40 Swaged Standoff Fastener (Mates With K,L,M,N).
Enter Two or Three Characters Per D-Subminiature Selection Guide.								K = Internal D-Sub Guide Bushing with Right Angle Bracket With 0.420 Or 0.395 Hole Location.
<u>Connector Gender</u>								L = Internal D-Sub Guide Bushing With Right Angle Bracket With 0.340 Hole Location.
D = Dimpled Shell (Plug Only).								M = Internal D-Sub Guide Bushing With Right Angle Bracket With 0.420 Or 0.395 Hole Location And Push-On Fastener Board Lock.
P = Plug (Male).								N = Internal D-Sub Guide Bushing With Right Angle Bracket With 0.340 Hole Location And Push-On Fastener Board Lock.
R = Receptacle (Female).								P = Screw Lock Kit Male (Screw Retainer).
<u>Signal Contact Modifier</u>								Q = Screw Lock Kit (Female Screw Lock).
Blank, If None Required.								R = Ground Strap (Refer To Succeeding Pages).
See Signal Contact Modifiers Table For Selections. (Others Are Available. Contact Factory For More Options).								S = Loaded Guide Pin Plate (Refer To Succeeding Pages).
<u>Signal Contact Finish Code Modifier</u>								T = Loaded Reversed Guide Pin Plate (Refer To Succeeding Pages).
Blank, If None Required Or Standard Plating Of 0.000030 Gold Over Nickel.								<u>Size 8 Contact Finish Modifier</u>
A = 0.000050 Gold Over Nickel.								A = 0.000050 Gold Over Nickel.
C = 0.000050 Gold Over Copper.								B = 0.000030 Gold Over Nickel.
D = 0.000030 Gold Over Copper.								C = 0.000050 Gold Over Copper.
H = Non-Magnetic 0.000050 Gold Over Copper.								D = 0.000030 Gold Over Copper (Standard).
<u>Shell Finish Modifier</u>								J = Non-Magnetic Plating.
1 = Yellow Chromate Over Zinc (Standard).								<u>Size 8 Contact Modifier</u>
2 = Yellow Chromate Over Cadmium.								Enter Two Characters, Per Size 8 Contact Modifier Table. (Others Are Available. Contact Factory For More Options).
3 = Tin (Alternate RoHS).								
4 = Non-Magnetic.								
5 = Clear Trivalent Chromate Over Zinc (Standard RoHS).								



Dimensions are subject to change without notice.

555 Pond Drive • Wood Dale, IL 60191 • Toll Free (800)323-9562

D-SUB CONNECTOR PART NUMBER SELECTION SYSTEM

Signal Contact Modifiers

Contact Listing By Board Thickness		STRAIGHT				RIGHT ANGLE	
		WITHOUT STANDOFFS		WITH STANDOFFS		WITHOUT STANDOFFS	
CODE	DIAMETER	EXTENSION LENGTH	BOARD THICKNESS	EXTENSION LENGTH	BOARD THICKNESS	EXTENSION LENGTH	BOARD THICKNESS
E	.030 (0.76)	.125 (3.18)	.093 (2.36)	-	-	-	-
B	.040 (1.02)	.125 (3.18)	.093 (2.36)	-	-	-	-
M	.030 (0.76)	.156 (3.96)	.125 (3.18)	-	-	-	-
H	.040 (1.02)	.156 (3.96)	.125 (3.18)	-	-	-	-
Z	.030 (0.76)	.184 (4.67)	.156 (3.96)	-	-	-	-
X	.040 (1.02)	.184 (4.67)	.156 (3.96)	-	-	-	-
J	.030 (0.76)	.204 (5.18)	.184 (4.67)	.089 (2.26)	.062 (1.57)	-	-
A	.040 (1.02)	.265 (6.73)	.250 (6.35)	.150 (3.81)	.125 (3.18)	-	-
F	.030 (0.76)	-	-	-	-	0.93 (2.36)	.062 (1.57)
G	.024 (0.61)	-	-	-	-	.156 (3.96)	.125 (3.18)
S	SOLDERCUP						

Size 8 Contact Modifiers

- 4: Modifier- 50 Ohm Coax (0.030" Center Pin).
 4A- Straight PCB.
 4B- Right Angle PCB 0.370 From Flange.
 4C- Right Angle PCB 0.470 From Flange (D Size Only).
 4D- Right Angle PCB 0.270 From Flange.
- 5: Modifier- Standard Coax Modifier (0.040" Center Pin).
 5A- Straight PCB.
 5B- Right Angle PCB 0.370 From Flange.
 5D- Right Angle PCB 0.270 From Flange.
- 6: Modifier- PKZ Coax.
 6A- Straight PCB.
 6B- Right Angle PCB 0.370 From Flange.
 6D- Right Angle PCB 0.270 From Flange.
 6F- Right Angle PCB 0.470 From Flange (D Size Only).
- 7: Modifier- 75 Ohm Coax.
 7B- Straight PCB.
 7H- Right Angle PCB 0.370 From Flange.

- 8: Modifier- High Voltage.
 8A- Straight Cable.
 8B- Right Angle Cable.
- 9: Modifier- High Power.
 9A- Straight PCB 20 Amp.
 9B- Straight PCB 40 Amp.
 9C- Right Angle PCB 20 Amp (0.570 Extension).
 9D- Right Angle PCB 40 Amp (0.570 Extension).
 9F- Right Angle PCB 40 Amp (0.810 Extension).
 9G- Straight Solder Cup 20 Amp.
 9H- Straight Solder Cup 40 Amp.
 9J- Right Angle Solder Cup 20 Amp.
 9K- Right Angle Solder Cup 40 Amp.
 9R- Right Angle Solder Cup 10 Amp.
 9S- Straight Solder Cup 10 Amp.
 9T- Straight Crimp 10 Amp.
 9U- Straight Crimp 20 Amp.
 9W- Straight Crimp 40 Amp.

Notes:

For Mixed Size 8 Combinations (i.e. Coax With Power)- Please Consult Factory.
 Coaxial Contacts Are Ordered Separately.



Dimensions are subject to change without notice.

555 Pond Drive • Wood Dale, IL 60191 • Toll Free (800)323-9562

PART NUMBER EXAMPLE

Description of D-Sub Requirement

Connectors with a 13W3 insulator configuration are required. The connectors are to have right angle female (socket) signal contacts and 75 ohm right angle stamped and formed size 8 contacts. These connectors will ultimately be mounted on .125 inch thick PC boards with board locks (push-ons) attached to right angle brackets. The finish on the signal contacts and the size 8 contacts is to be 30 microinches of gold over nickel. Shell finish is to be yellow chromate over zinc.

Requirement

Digit By Digit Part Number Creation

- | | | |
|---|----------|---|
| <ul style="list-style-type: none"> ■ Standard Series Connector ■ 13W3 Insulator ■ Receptacle (Socket Signal Contacts) ■ Right Angle Signal Contacts for .125 thick PC Board ■ Standard .000030 Gold over Nickel on Signal Contacts ■ Standard Yellow Chromate over Zinc on Shell ■ Right Angle PC Receptacles, PKZ ■ Standard Plating .000030 Gold over copper ■ #4-40 Standoffs with Right Angle Brackets & Push-On Fasteners | <p>→</p> | <p>SERIES PREFIX: P</p> <p>INSULATOR TYPE MODIFIER: 133</p> <p>CONNECTOR STYLE MODIFIER: R</p> <p>SIGNAL CONTACT MODIFIER: G</p> <p>SIGNAL FINISH CODE MODIFIER: BLANK</p> <p>SHELL FINISH MODIFIER: 1</p> <p>SIZE 8 CONTACT MODIFIER: 6B</p> <p>SIZE 8 CONTACT FINISH MODIFIER: D</p> <p>MOUNTING HARDWARE MODIFIER: G</p> |
|---|----------|---|

P
133
R
G
1
6
B
D
G
= P133RG16BDG

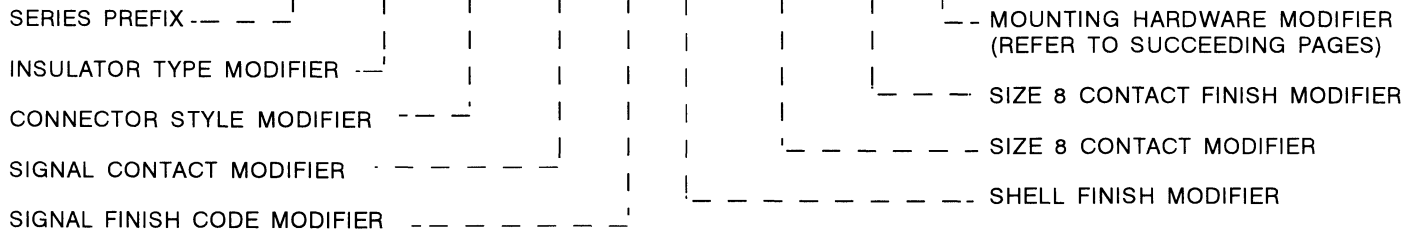

MATING INTERFACE

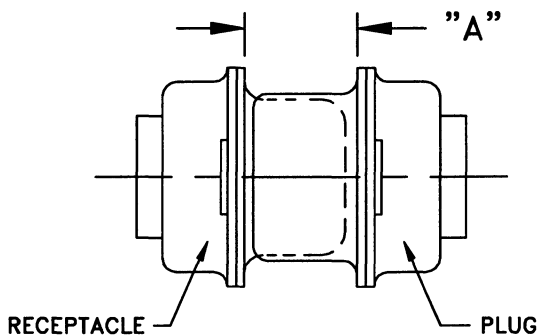

Shell Size	"A" Dimension
E,A	$.265 \pm .015$
B,C,D	$.256 \pm .015$



SHELL DIMENSIONS

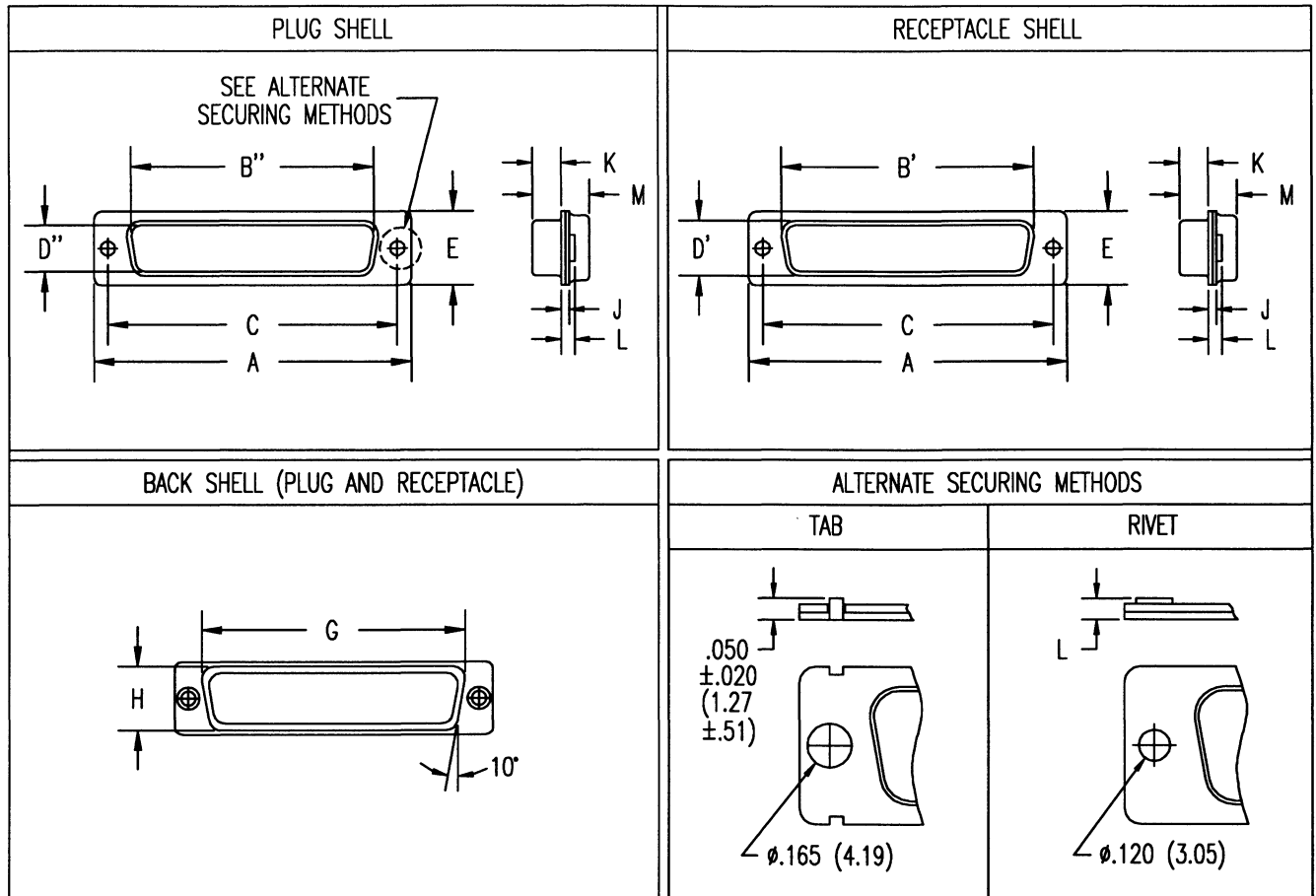

Shell Size	Gender	A ±.015 (±.38)	B' ±.005 (±.13)	B'' ±.005 (±.13)	C ±.005 (±.13)	D' ±.005 (±.13)	D'' ±.005 (±.13)	E ±.015 (±.38)	G ±.010 (±.25)	H ±.010 (±.25)	J ±.010 (±.25)	K	L	M ±.010 (±.25)
E	P	1.213 (30.81)	—	.666 (16.92)	.984 (24.99)	—	.329 (8.36)	.494 (12.55)	.759 (19.28)	.422 (10.72)	.030 (.76)	.229/.238 (5.82/6.05)	.035/.060 (.89/1.52)	.422 (10.72)
E	R	1.213 (30.81)	.643 (16.33)	—	.984 (24.99)	.311 (7.90)	—	.494 (12.55)	.759 (19.28)	.422 (10.72)	.030 (.76)	.238/.248 (6.05/6.30)	.035/.060 (.89/1.52)	.429 (10.90)
A	P	1.541 (39.14)	—	.994 (25.25)	1.312 (33.32)	—	.329 (8.36)	.494 (12.55)	1.083 (27.51)	.422 (10.72)	.030 (.76)	.229/.238 (5.82/6.05)	.035/.060 (.89/1.52)	.422 (10.72)
A	R	1.541 (39.14)	.971 (24.66)	—	1.312 (33.32)	.311 (7.90)	—	.494 (12.55)	1.083 (27.51)	.422 (10.72)	.030 (.76)	.238/.248 (6.05/6.30)	.035/.060 (.89/1.52)	.429 (10.90)
B	P	2.088 (53.04)	—	1.534 (38.96)	1.852 (47.04)	—	.329 (8.36)	.494 (12.55)	1.625 (41.28)	.422 (10.72)	.039 (.99)	.224/.236 (5.69/5.99)	.050/.070 (1.27/1.78)	.426 (10.82)
B	R	2.088 (53.04)	1.511 (38.38)	—	1.852 (47.04)	.311 (7.90)	—	.494 (12.55)	1.625 (41.28)	.422 (10.72)	.030 (.76)	.238/.248 (6.05/6.30)	.035/.060 (.89/1.52)	.429 (10.90)
C	P	2.729 (69.32)	—	2.182 (55.42)	2.500 (63.50)	—	.329 (8.36)	.494 (12.55)	2.272 (57.71)	.422 (10.72)	.039 (.99)	.224/.236 (5.69/5.99)	.050/.070 (1.27/1.78)	.426 (10.82)
C	R	2.729 (69.32)	2.159 (54.84)	—	2.500 (63.50)	.311 (7.90)	—	.494 (12.55)	2.272 (57.71)	.422 (10.72)	.030 (.76)	.238/.248 (6.05/6.30)	.035/.060 (.89/1.52)	.429 (10.90)
D	P	2.635 (66.93)	—	2.079 (52.81)	2.406 (61.11)	—	.441 (11.20)	.605 (15.37)	2.178 (55.32)	.534 (13.56)	.039 (.99)	.224/.236 (5.69/5.99)	.050/.070 (1.27/1.78)	.426 (10.82)
D	R	2.635 (66.93)	2.064 (52.43)	—	2.406 (61.11)	.423 (10.74)	—	.605 (15.37)	2.178 (55.32)	.534 (13.56)	.030 (.76)	.238/.248 (6.05/6.30)	.035/.060 (.89/1.52)	.429 (10.90)

Gender: P: Plug (Pin Signal Contacts) R: Receptacle (Socket Signal Contacts)



THE PHOENIX COMPANY
of CHICAGO, INC.

Dimensions are subject to change without notice.

555 Pond Drive ■ Wood Dale, IL 60191-1192 ■ Toll Free (800)323-9562