

CAD DRAWING - NO MANUAL REVISIONS

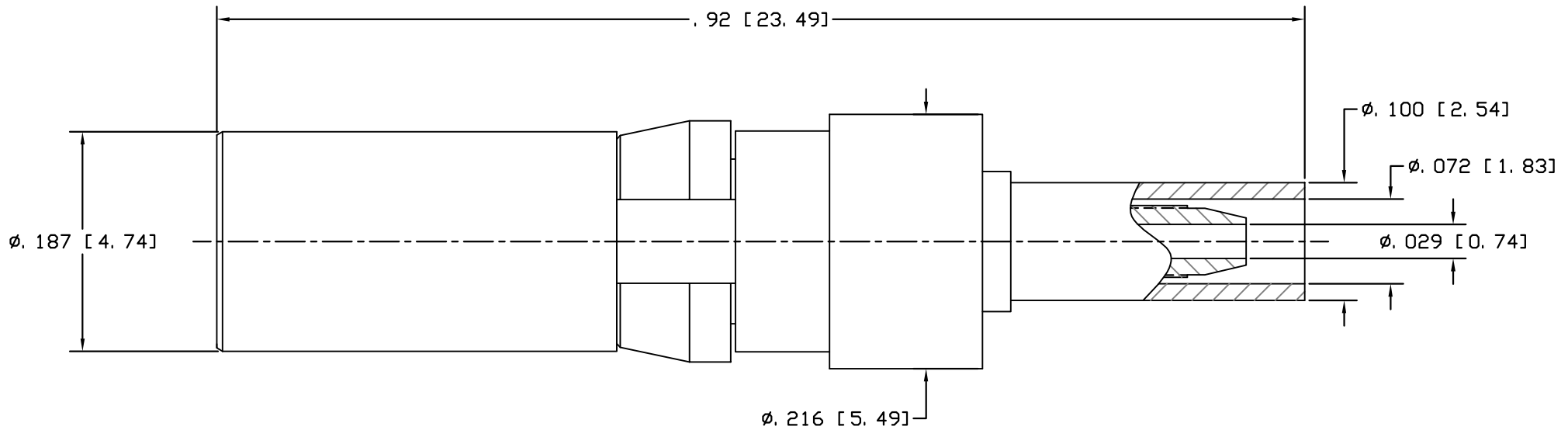

NOTES:

1. DESIGN AND INTERFACE PER I. D. S. -62.
2. ACCOMMODATES HIROSE 1.13mm OR EQUIVALENT CABLES.
3. CRIMP USING .081 HEX DIE (DANIEL Y1547P).
4. CONTACT AND FERRULE ARE SUPPLIED LOOSE.
5. "J" PLATING - TEST TO 20 GAMMA MAX.

A	PER ECN 11699	06/26/13	JEM
REV.	DESCRIPTION	DATE	APPR.

PALCO CONNECTOR

22 GREAT HILL RD., NAUGATUCK, CT 06770
 UNLESS OTHERWISE SPECIFIED, PALCO WORKMANSHIP STANDARDS APPLY
 TOLERANCES ON: DECIMALS: XX ± .01 .XXX ± .005 ANGLES ± 1/2° 32'
 DIMENSIONS IN INCHES OR (METRIC) DO NOT SCALE PRINTS

DRAWN JEM	CHECKED JEM	ENGINEER JEM	APPROVED JEM	FSCM 58167
		DESCRIPTION SIZE 8 PkZ, HMC RECEPTACLE, DIRECT CRIMP		
DATE 06/26/13	DRAWING NO. 62-1902-0290		PLATING OPT. J	

CATALOG ITEM

CABLE ASSEMBLY PROCEDURE	
P/N	62-1902-0290
PAGE 1 OF 1	DATE: 06/27/13
DRAWN: JEM	APPROVED: JEM
FOR USE WITH HIROSE 1.13mm CABLE	

PALEO
CONNECTOR

22 GREAT HILL ROAD, NAUGATUCK, CT. 06770
PHONE: (203) 729-9090 FAX: (203) 723-1794

REV	DESCRIPTION	DATE	APPR
A	PER ECN 11699	06/27/13	JEM

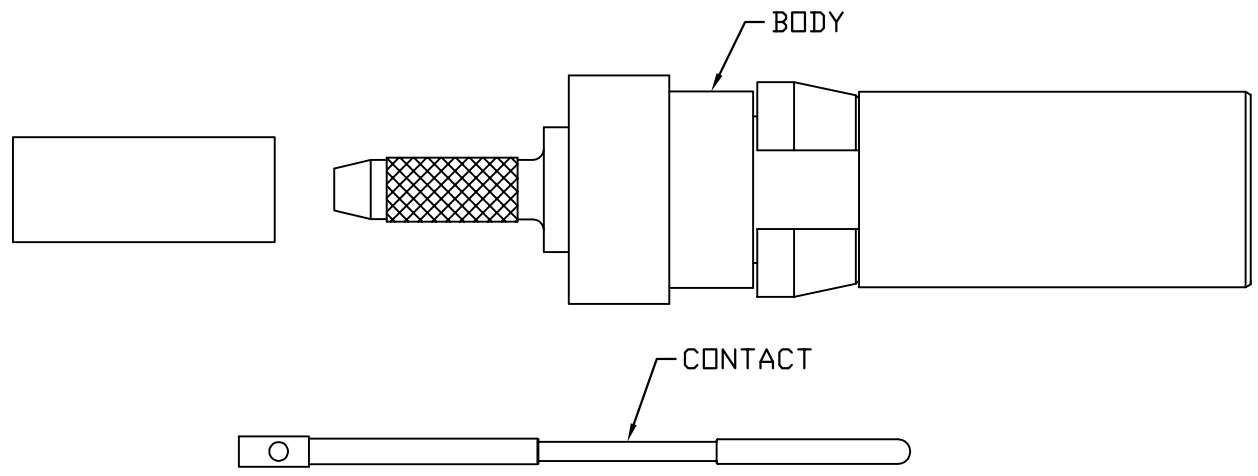

STEP 1.
TRIM CABLE TO DIMENSIONS
SHOWN, TIN CENTER CONDUCTOR.

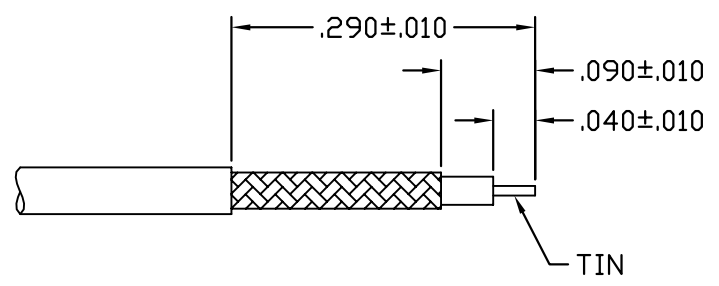

STEP 2.
SOLDER CONTACT TO CENTER CONDUCTOR.
CENTER CONDUCTOR MUST BUTT DIELECTRIC.

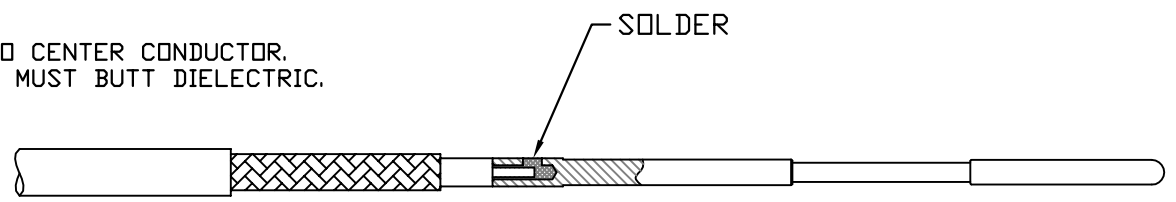

STEP 3.
SLIDE FERRULE OVER CABLE. FLARE BRAID
BY ROTATE CABLE DIELECTRIC.

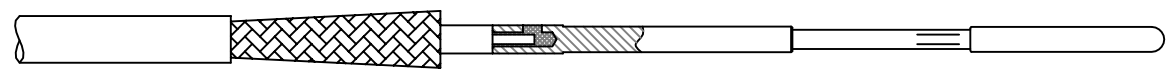

STEP 4.
INSERT CABLE ASSEMBLY
INTO BACK OF CONNECTOR
BODY UNTIL CABLE BOTTOMS.
SLIDE FERRULE UP AGAINST
SHOULDER OF BODY. CRIMP
FERRULE USING .0881 HEX
DIE (DANIELS Y1547P).

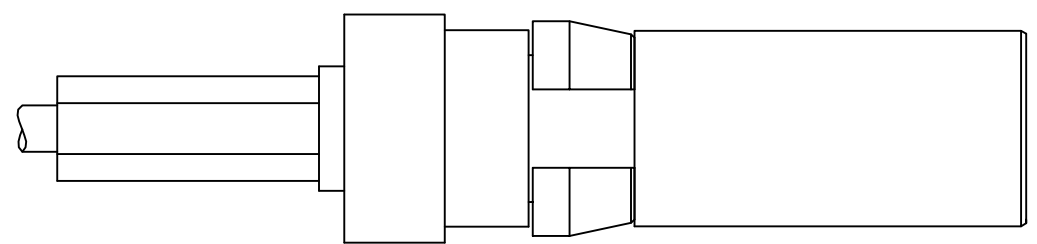

NOTES:

- 1) MATERIAL: ACETAL COPOLYMER
- 2) COLOR: NATURAL / WHITE.
- 3) REQUIREMENTS DO NOT INCLUDE RF CONTACTS, SEE INDIVIDUAL SPECIFICATION SHEETS.
- 4) UNLESS OTHERWISE SPECIFIED, DIMENSION ARE FOR REFERENCE ONLY

REVISIONS			
REV	DESCRIPTION	DATE	APPROVED
A	ECN# 11774 RELEASED FOR PRODUCTION	9/30/2013	

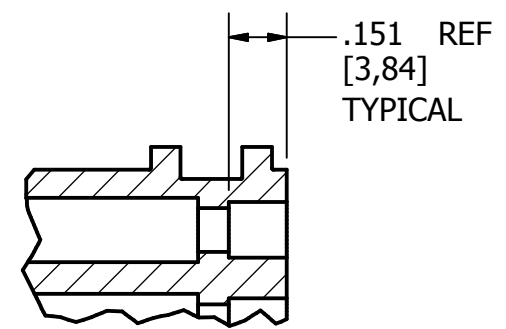
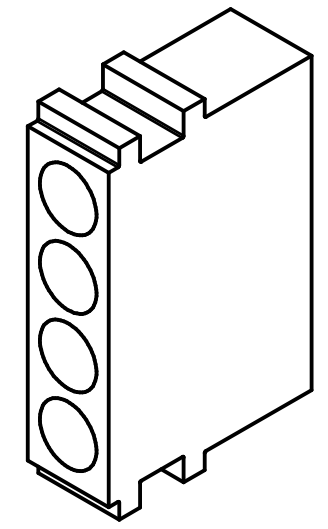
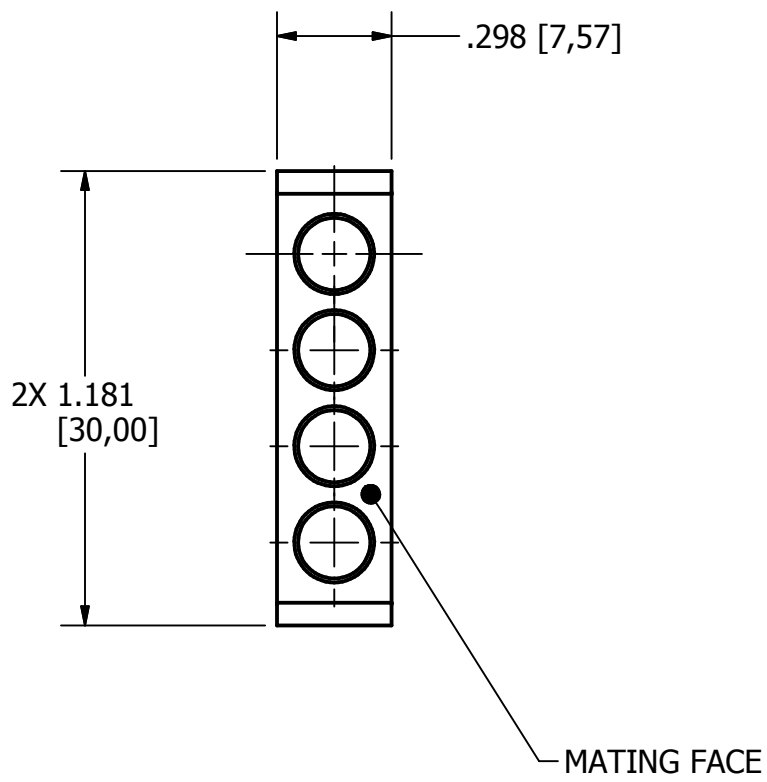
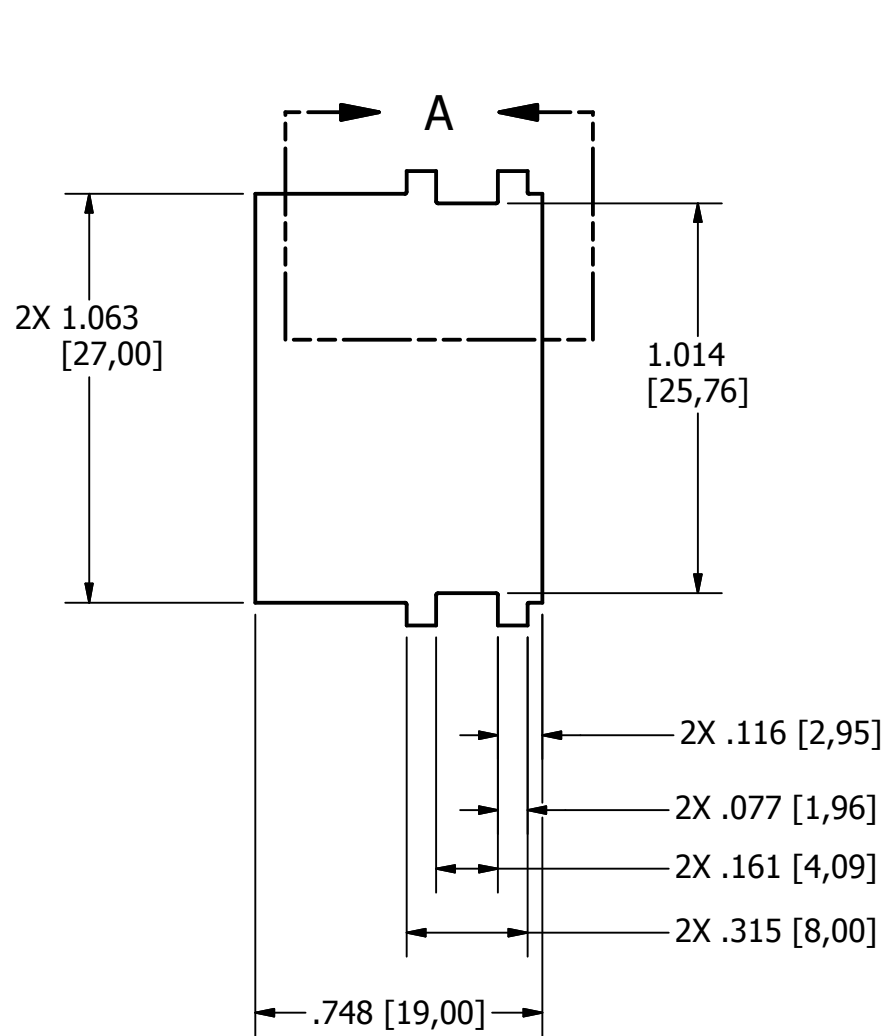

CONTACT RETENTION
FEATURE LOCATION
SCALE: 2 : 1

~~UNLESS OTHERWISE SPECIFIED
DIMENSIONS ARE IN INCHES
TOLERANCES ARE:
FRACTIONS DECIMALS ANGLES
± 1/64 ± .01 ± 1/2°
± .003 ± .003~~

THE INFORMATION DISCLOSED IN
THIS DOCUMENT IS CONFIDENTIAL
AND PROPRIETARY TO PHOENIX CO.
INC. AND MAY NOT BE USED FOR
MANUFACTURE OR ANY OTHER
PURPOSE WITHOUT THE WRITTEN
CONSENT OF MIL-CON INC.

NEXT ASSEMBLY	USED ON

CONTRACT NO.	
APPROVALS	DATE
DRAWN R.M.Bradley	8/8/2013
CHECKED	
ISSUED	

<i>The PHOENIX Company of Chicago™</i>			
HOUSING, 4 POSITION, SIZE 8 PLUG, MODULAR RAIL TYPE, MACHINED			
SIZE B	FSCM NO. 60563	DWG. NO. PMC4W4P	REV. A

APPLICATIONS	DO NOT SCALE DRAWING	SCALE 2 X 1	SHEET 1 OF 1
--------------	----------------------	--------------------	----------------------------

NOTES:

- 1) MATERIAL: ACETAL COPOLYMER
- 2) COLOR: NATURAL / WHITE.
- 3) REQUIREMENTS DO NOT INCLUDE RF CONTACTS, SEE INDIVIDUAL SPECIFICATION SHEETS.
- 4) UNLESS OTHERWISE SPECIFIED, DIMENSION ARE FOR REFERENCE ONLY

REVISIONS			
REV	DESCRIPTION	DATE	APPROVED
A	ECN# 11774 RELEASED FOR PRODUCTION	9/30/2013	

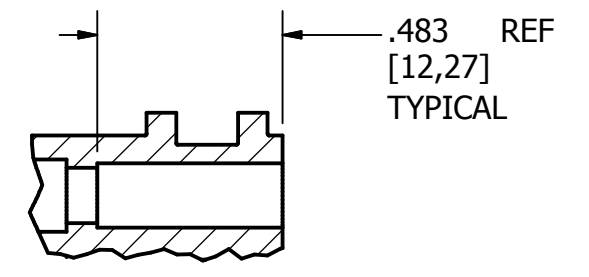
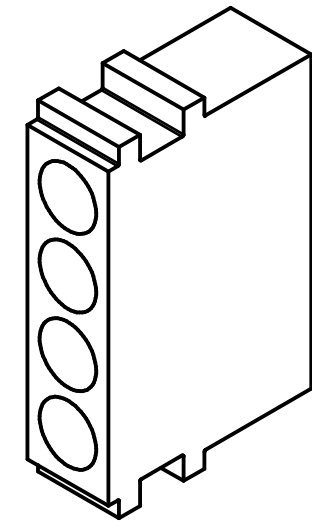
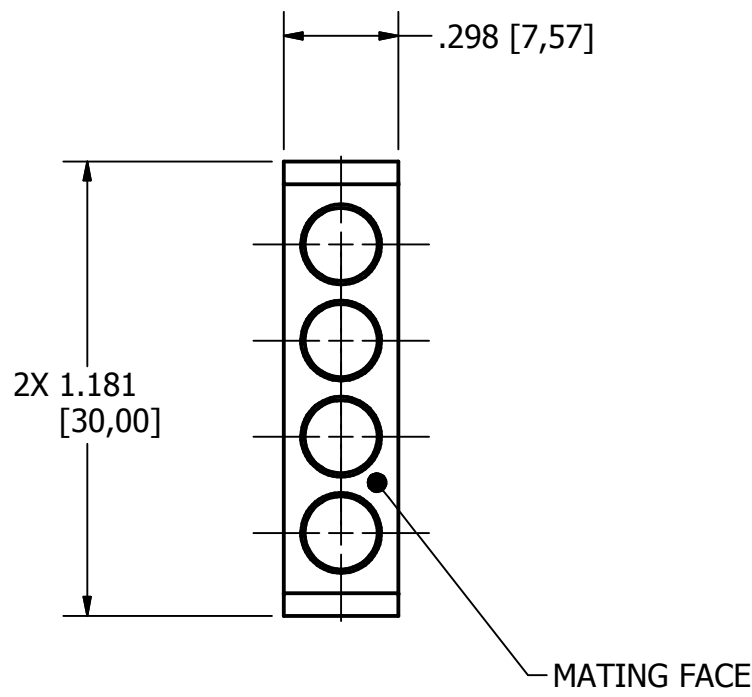
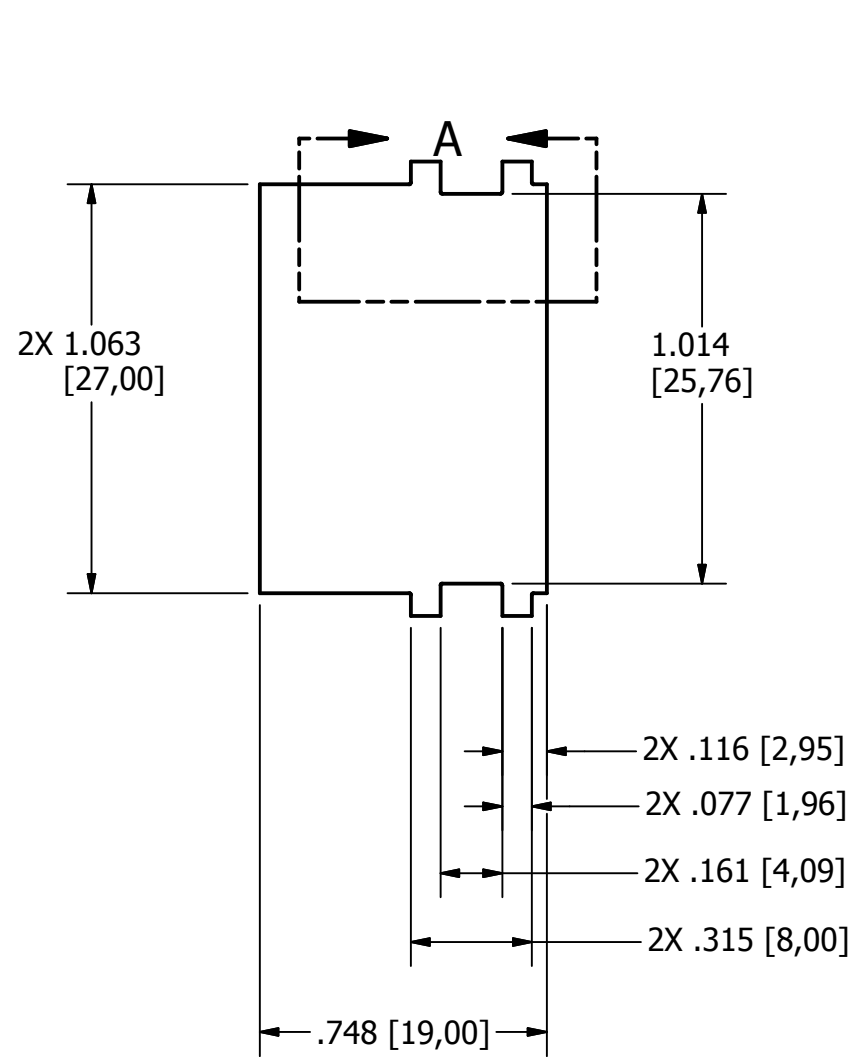

CONTACT RETENTION
FEATURE LOCATION
SCALE: 2 : 1

UNLESS OTHERWISE SPECIFIED
DIMENSIONS ARE IN INCHES
TOLERANCES ARE:
FRACTIONS DECIMALS ANGLES
±1/64 ±.01 ±1/2°
±.003 ±.003

THE INFORMATION DISCLOSED IN
THIS DOCUMENT IS CONFIDENTIAL
AND PROPRIETARY TO PHOENIX CO.
INC. AND MAY NOT BE USED FOR
MANUFACTURE OR ANY OTHER
PURPOSE WITHOUT THE WRITTEN
CONSENT OF MIL-CON INC.

NEXT ASSEMBLY	USED ON

CONTRACT NO.	
APPROVALS	DATE
DRAWN R.M.Bradley	8/8/2013
CHECKED	
ISSUED	

<i>The PHOENIX Company of Chicago™</i>			
HOUSING, 4 POSITION, SIZE 8 RECEPTACLE, MODULAR RAIL TYPE, MACHINED			
SIZE B	FSCM NO. 60563	DWG. NO. PMC4W4R	REV. A

INTERFACE DESIGN STANDARD

IDS-62J

PAGE 1 OF 1

DATE: 02/27/13

DRAWN: JEM

APPROVED: JEM



22 GREAT HILL ROAD, NAUGATUCK, CT. 06770
 PHONE: (203) 729-9090 FAX: (203) 723-1794

REV	DESCRIPTION	DATE	APPR
A	REL. ECN 11658	05/07/13	JEM
B	PER ECN 11688	06/05/13	JEM
C	PER ECN 11750	08/13/12	JEM

DESCRIPTION: 62J SERIES, SIZE 8 PKZ,[®] HIGH MATING CYCLE
 NON-MAGNETIC PER BS EN 122340.

MECHANICAL

MATERIALS:

PLUG AND RECEPTACLE BODIES, FERRULES AND CAPS - NON-MAGNETIC BRASS.
 CENTER AND OUTER CONTACTS - BERYLLIUM COPPER PER ASTM-B-197 or NON-MAGNETIC BRASS.
 CLIP RING - BERYLLIUM COPPER PER ASTM-B-196.
 INSULATORS - VIRGIN TEFLON (PTFE) PER ASTM D 1710

FINISHES (ADD LETTER 'J' TO END OF PART NUMBER)

GOLD PER MIL-G-45204.
 CONTACTS - .000050 MIN. GOLD.
 BODIES - .000050 MIN. GOLD.
 CLIP RINGS: UNPLATED.
 OTHER METAL PARTS: GOLD PLATED TO MEET
 THE ENVIRONMENTAL REQUIREMENTS.
 RESIDUAL MAGNETISM 20 GAMMA MAX.
 CONFORMS TO BS EN 122340 STANDARDS.

MATING CHARACTERISTICS

INSERTION ————— 1.0 LBS MAXIMUM
 0.5 LBS NOMINAL
 WITHDRAWAL ————— 1.5 OZ. MINIMUM
 4.0 OZ. NOMINAL
 HOUSING RETENTION ————— 12 LBS. MIN.
 AXIAL MATING TOLERANCE — .090" MAX.

ELECTRICALS

FREQUENCY RANGE: DC TO 6 GHz.
 (CONFIGURATION DEPENDENT)
 VOLTAGE RATING STRAIGHT: 1000 VRMS.
 VOLTAGE RATING ANGLED: 800 VRMS.
 CURRENT RATING: 5 AMPS.
 INSULATION RESISTANCE: 2000 MEGOHMS MIN.
 INSERTION LOSS: .4 f(GHz) dB

CONTACT RESISTANCE: CENTER CONTACT 5 MILLIOHMS
 CONTACT RESISTANCE: OUTER CONTACT 3 MILLIOHMS
 VSWR:
 1.10 + .01 (f) GHz., RG-405 CABLE (To 6 GHz).
 1.15 + .02 (f) GHz., RG-316 CABLE (To 1.5 GHz).
 1.15 + .03 (f) GHz., RG-178 CABLE (To 1.5 GHz).

ENVIRONMENTAL

OPERATING TEMPERATURE: -55°C to +125°C (-67°F - 257°F)
 VIBRATION: MIL-STD-202, METHOD 204, TEST CONDITION D.
 SHOCK: MIL-STD-202, METHOD 213, TEST CONDITION I.
 SALT SPRAY: MIL-STD-1344, METHOD 1001, CONDITION B.
 DURABILITY: 60,000 CYCLES MIN.
 THERMAL SHOCK: MEL-STD-202, METHOD 107, TEST
 CONDITION B, EXCEPT HIGH TEMPERATURE SHALL
 BE +85°C.
 MOISTURE RESISTANCE: MIL-STD-202, METHOD 106.
 NO MEASUREMENT AT HIGH HUMIDITY. INSULATION
 RESISTANCE 2000 MEGOHMS AFTER HUMIDITY.

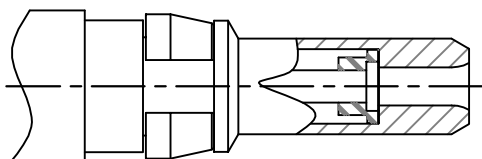

PLUG

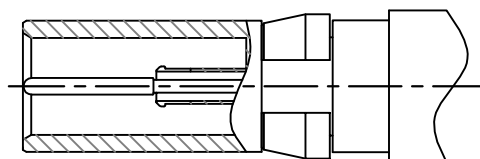

RECEPTACLE