

CAD DRAWING - NO MANUAL REVISIONS

THESE ITEM(S)/TECHNICAL DATA ARE CONTROLLED BY THE DEPARTMENT OF STATE, INTERNATIONAL TRAFFIC IN ARMS REGULATION(S) (ITAR) 22 CFR PARTS 120-130 AND CAN NOT BE EXPORTED FROM THE UNITED STATES OR SHARED WITH A FOREIGN NATIONAL WITHOUT PRIOR APPROVAL FROM THE UNITED STATES GOVERNMENT.

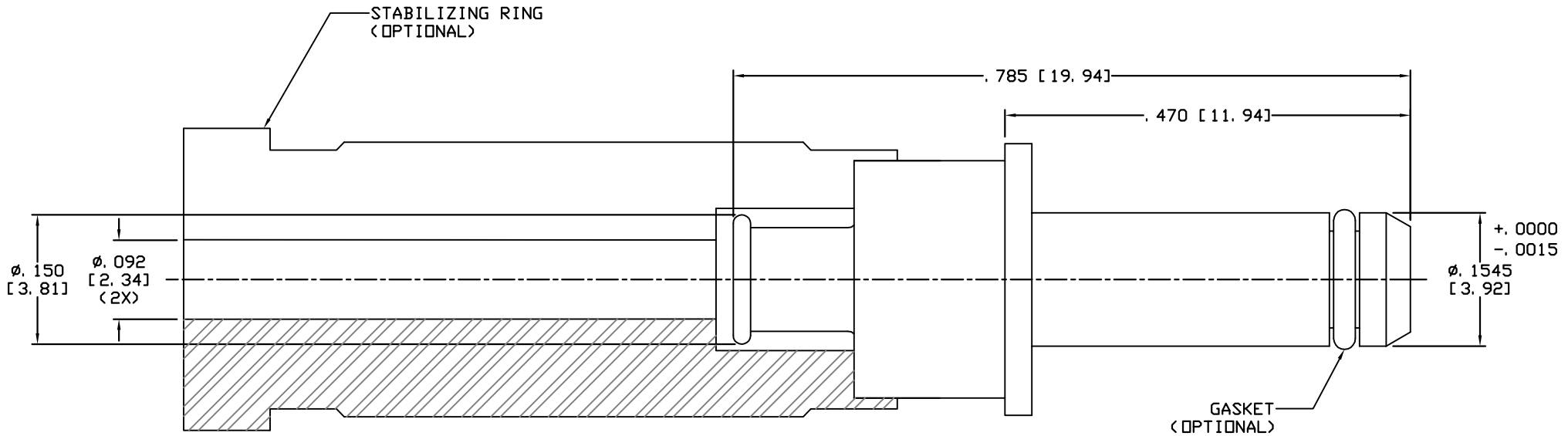

68-0020-0861	WITHOUT GASKET
68-0021-0861	WITH GASKET
68-0022-0861	WITH GASKET AND STABILIZING RING

NOTES:

1. PROCESS ALL ECNs PER DS-12.
2. DESIGN AND INTERFACE PER I. D. S. -68.
3. FOR USE WITH .086 OR EQUIVALENT CABLE.
4. USE IN ARING 600 CONNECTOR PER MIL-C-83527, SIZE #8.
5. USE INSERTION/WITHDRAWAL TOOL T-0617.
6. STABILIZING RING SUPPLIED LOOSE.
7. RAYTHEON DRAWING 7018414, REV. D.

H	PER ECN 11766	09/12/13	JEM	PALCO CONNECTOR 22 GREAT HILL RD., NAUGATUCK, CT 06770 UNLESS OTHERWISE SPECIFIED, PALCO WORKMANSHIP STANDARDS APPLY TOLERANCES ON: DECIMALS: XX ±.01 .XXX ±.005 ANGLES ±1/2° 32' DIMENSIONS IN INCHES OR (METRIC) DO NOT SCALE PRINTS	DRAWN	CHECKED	ENGINEER	APPROVED	FSCM	
G	PER ECN 10634	10/06/10	MS		EK	JEM	HN	JEM	58167	
F	PER ECN 10001	08/25/09	MS			DESCRIPTION				PKZ PLUG, STRAIGHT DIRECT SOLDER
E	PER ECN 8206	10/03/05	JEM			DATE	DRAWING NO.	PLATING OPT.		
D	PER ECN 8190	09/14/05	JEM		11/02/04	68-002X-0861	A, B, C, D			
REV.	DESCRIPTION	DATE	APPR.	EPR 5508						

CABLE ASSEMBLY PROCEDURE
P/N 68-002X-0861
PAGE 1 OF 2 DATE: 10/06/97
DRAWN: EK APPROVED: JEM
FOR USE WITH RG-405 CABLE

PALEO
CONNECTOR
22 GREAT HILL ROAD, NAUGATUCK, CT. 06770
PHONE: (203) 729-9090 FAX: (203) 723-1794

REV	DESCRIPTION	DATE	APPR
E	PER ECN 8206	10/03/05	JEM
F	PER ECN 10,001	8/25/09	MS
G	PER ECN 10634	10/06/10	MS
H	PER ECN 11766	09/12/13	JEM

RG-405 CABLE

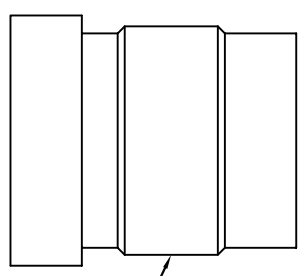

STABILIZING RING
(68-0022-0861 ONLY)

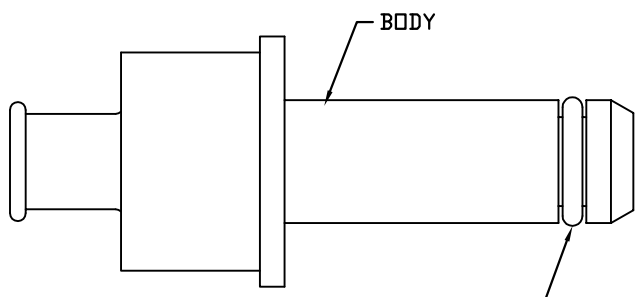

GASKET
(OPTIONAL)

STEP 1
*STRIP CABLE TO DIMENSION SHOWN.
POINT END 90°.

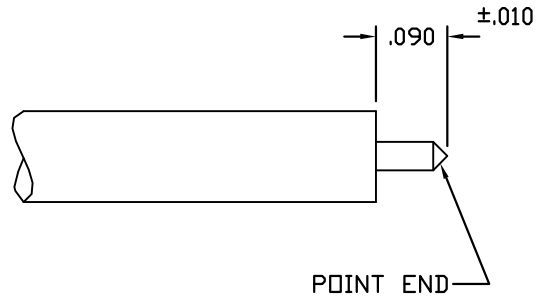

*NOTE: ON 68-0022-0861 SLIDE STABILIZING RING ON FIRST.

STEP 2
SLIDE PREPARED CABLE INTO CONNECTOR
BODY AND SOLDER, CLEAN SOLDER JOINT.

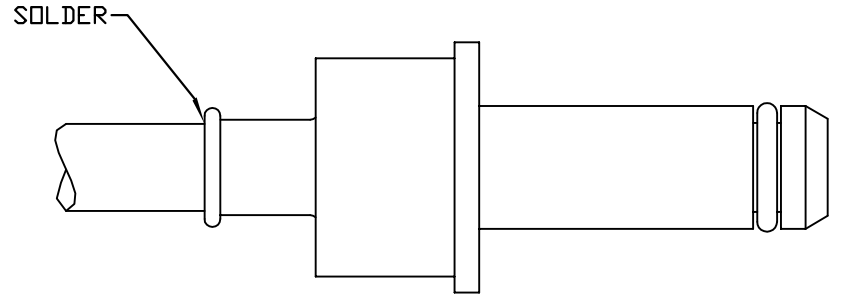

CABLE ASSEMBLY PROCEDURE	
P/N	68-002X-0861
PAGE 2 OF 2	DATE: 10/06/97
DRAWN: EK	APPROVED: JEM
FOR USE WITH TFLEX 405 CABLE	

PALEO
CONNECTOR

22 GREAT HILL ROAD, NAUGATUCK, CT. 06770
PHONE: (203) 729-9090 FAX: (203) 723-1794

REV	DESCRIPTION	DATE	APPR
D	PER ECN 8190	09/14/05	JEM
E	PER ECN 8206	10/03/05	JEM
F	PER ECN 10,001	8/25/09	MS
G	PER ECN 10634	10/06/10	MS

TFLEX 405 CABLE

USE SHRINK TUBING.

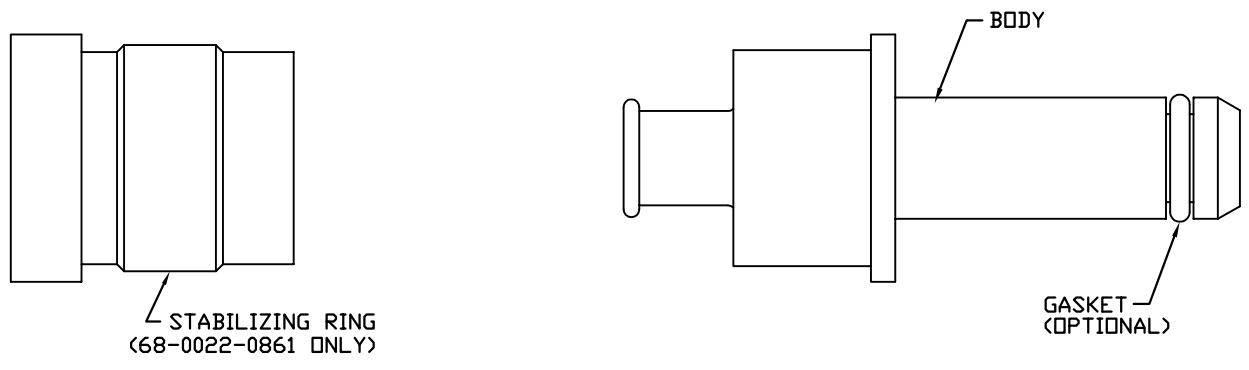

STEP 1

DIP END OF CABLE INTO FLUX AND THEN TIN DIP CABLE TO DIMENTION SHOWN USING KESTER 60/40 SOLDER @ 500° F FOR SIX SECONDS MAX.

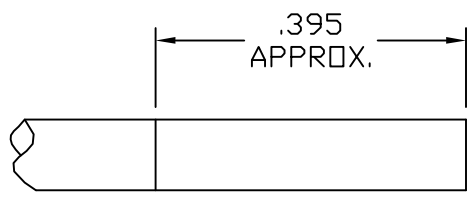

STEP 2

TRIM CABLE TO DIMENSIONS SHOWN. POINT TIP OF INNER CONDUCTOR AS SHOWN.

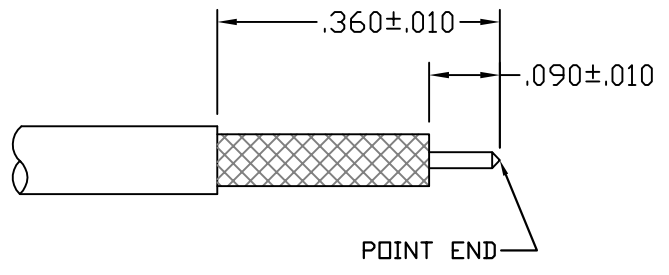

*NOTE: ON 68-0022-0861 SLIDE STABILIZING RING ON FIRST.

STEP 3

SLIDE PREPARED CABLE INTO CONNECTOR BODY AND SOLDER, CLEAN SOLDER JOINT.

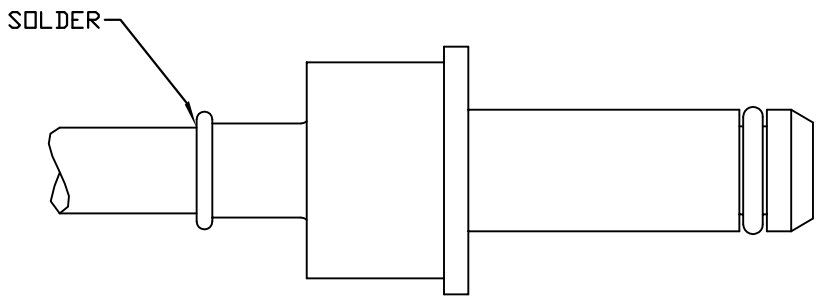

INTERFACE DESIGN STANDARD	
IDS-68	
PAGE 1 OF 2	DATE: 06/29/99
DRAWN: JEM	APPROVED: HN

PALEO
CONNECTOR

22 GREAT HILL ROAD, NAUGATUCK, CT. 06770
PHONE: (203) 729-9090 FAX: (203) 723-1794

REV	DESCRIPTION	DATE	APPR
B	PER ECN 9588	10/27/08	HN
C	PER ECN 9935	05/22/09	JEM
D	PER ECN 10145	01/20/10	JEM
E	PER ECN 11479	10/19/12	JEM

DESCRIPTION: 68 SERIES, SIZE 8 PKZ®, FOR ARINC

MECHANICAL

MATERIALS

BODIES:

PLUG BODIES - BRASS PER ASTM B 16.
RECEPTACLE BODIES - BRASS PER ASTM B 16.

PLATING:

GOLDE PER MIL-G-45204.
COPPER PER MIL-C-14550.
NICKEL PER QQ-N-290.

INSULATORS - TEFLON (PTFE) PER ASTM D 1457.
RETAINING RING - BERYLLIUM COPPER PER ASTM B 196.
MALE CONTACT - BERYLLIUM COPPER PER ASTM B 197.
FEMALE CONTACTS - BERYLLIUM COPPER PER ASTM B 197.
WEATHER SEAL GASKET (OPTIONAL) -
SILICONE RUBBER PER ZZ-R-765.
EMI GASKET - BERYLLIUM COPPER ASTM B 196.

FINISHES (ADD LETTER TO END OF PART NUMBER)

"A" - .000050 MIN. GOLD OVER NICKEL
"B" - .000030 MIN. GOLD OVER NICKEL
"C" - .000050 MIN. GOLD OVER COPPER
"D" - .000030 MIN. GOLD OVER COPPER

MATING CHARACTERISTICS

OUTER BODIES _____ 3 LBS MAX. INSERTION.
2 OZ. MIN. WITHDRAWL.
CENTER CONTACTS _____ 32 OZ. MAX. INSERTION.
.5 OZ. MIN. WITHDRAWL.
HOUSING RETENTION _____ 12 LBS. MIN.
AXIAL MATING TOLERANCE _____ .090

ELECTRICALS

FREQUENCY RANGE: DC TO 32 GHz.
VOLTAGE RATING STRAIGHT: 1000 VRMS.
VOLTAGE RATING ANGLED: 800 VRMS.
CURRENT RATING: 5 AMPS.
INSULATION RESISTANCE: 2000 MEGOHMS MIN.
INSERION LOSS: $.06 \sqrt{f(\text{GHz})}$ dB

CONTACT RESISTANCE: CENTER CONTACT 5 MILLIOHMS
CONTACT RESISTANCE: OUTER CONTACT 3 MILLIOHMS
VSWR: 1.08 + .009(f) GHz., RG-402 CABLE.
1.15 + .02 (f) GHz., RG-174 & RG-316 CABLES.
1.15 + .01 (f) GHz., RG-142, 223, 303 & 400 CABLES.

ENVIRONMENTAL

OPERATING TEMPERATURE: -55°C to +165°C
VIBRATION: MIL-STD-202, METHOD 204, TEST CONDITION D.
SHOCK: MIL-STD-202, METHOD 213, TEST CONDITION I.
SALT SPRAY: MIL-STD-1344, METHOD 1001, CONDITION B.
DURABILITY: 500 CYCLES.

THERMAL SHOCK: MIL-STD-202, METHOD 107, TEST
CONDITION B, EXCEPT HIGH TEMPERATURE SHALL
BE +85°C.
MOISTURE RESISTANCE: MIL-STD-202, METHOD 106.
NO MEASUREMENT AT HIGH HUMIDITY. INSULATION
RESISTANCE 2000 MEGOHMS AFTER HUMIDITY.

